



Use & Care

G U I D E

Self-Cleaning Gas Range

A Note to You	2
Range Safety	3
Parts and Features	5
Using Your Range	6
Using the Self-Cleaning Cycle	24
Caring for Your Range	28
Troubleshooting	34
Requesting Assistance or Service	36
Index	39
Warranty	40

1-800-253-1301

Call our Consumer Assistance Center with questions or comments.

TO THE INSTALLER: PLEASE LEAVE THIS INSTRUCTION BOOK WITH THE UNIT.

TO THE CONSUMER: PLEASE READ AND KEEP THIS BOOK FOR FUTURE REFERENCE.

Super Capacity 465 with ACCUBAKE® System

4.65 Cubic Foot Oven

MODEL GS395LEG GS395LEH

8272338

www.whirlpool.com

A NOTE TO YOU

Thank you for buying a WHIRLPOOL® appliance.

The Whirlpool Brand is committed to designing quality products that consistently perform for you to make your life easier. To ensure that you enjoy years of trouble-free operation, we developed this Use and Care Guide. It is full of valuable information about how to operate and maintain your appliance properly and safely. Please read it carefully.

Also, please complete and mail the **Product Registration Card** provided with your appliance. The card helps us notify you about any new information on your appliance.

Please record your model's information.

Whenever you call to request service for your appliance, you need to know your complete model number and serial number. You can find this information on the model and serial number label/plate (see diagram in the "Parts and Features" section).

Please also record the purchase date of your appliance and your dealer's name, address, and telephone number.

Model Number _____
Serial Number _____
Purchase Date _____
Dealer Name _____
Dealer Address _____
Dealer Phone _____

Keep this book and the sales slip together in a safe place for future reference. It is important for you to save your sales receipt showing the date of purchase. Proof of purchase will assure you of in-warranty service.

Our Consumer Assistance Center number is toll free.

1-800-253-1301

To find detailed product information, the location of the nearest Whirlpool dealer or designated servicer, to purchase an accessory item, or register your appliance on-line, please visit our Web site at www.whirlpool.com

WARNING: If the information in this manual is not followed exactly, a fire or explosion may result causing property damage, personal injury or death.

- Do not store or use gasoline or other flammable vapors and liquids in the vicinity of this or any other appliance.
- **WHAT TO DO IF YOU SMELL GAS**
 - Do not try to light any appliance.
 - Do not touch any electrical switch; do not use any phone in your building.
 - Immediately call your gas supplier from a neighbor's phone. Follow the gas supplier's instructions.
 - If you cannot reach your gas supplier, call the fire department.
- Installation and service must be performed by a qualified installer, service agency or the gas supplier.

RANGE SAFETY

Your safety and the safety of others is very important.

We have provided many important safety messages in this manual and on your appliance. Always read and obey all safety messages.



This is the safety alert symbol.

This symbol alerts you to hazards that can kill or hurt you and others.

All safety messages will be preceded by the safety alert symbol and the word "DANGER" or "WARNING." These words mean:

⚠ DANGER

You **will** be killed or seriously injured if you don't follow instructions.

⚠ WARNING

You **can** be killed or seriously injured if you don't follow instructions.

All safety messages will identify the hazard, tell you how to reduce the chance of injury, and tell you what can happen if the instructions are not followed.

THE ANTI-TIP BRACKET

The range will not tip during normal use. However, the range can tip if you apply too much force or weight to the open door without the anti-tip bracket fastened down properly.



⚠ WARNING

Tip Over Hazard

A child or adult can tip the range and be killed.

Connect anti-tip bracket to rear range foot.

Reconnect the anti-tip bracket, if the range is moved.

See the installation instructions for details.

Failure to follow these instructions can result in death or serious burns to children and adults.

Anti-Tip Bracket

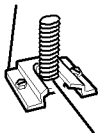

Range Foot

Making sure the anti-tip bracket is installed:

- Slide range forward.
- Look for the anti-tip bracket securely attached to floor.
- Slide range back so rear range foot is under anti-tip bracket.

continued on next page

IMPORTANT SAFETY INSTRUCTIONS

WARNING: To reduce the risk of fire, electrical shock, injury to persons, or damage when using the range, follow basic precautions, including the following:

• **WARNING:** TO REDUCE THE RISK OF TIPPING OF THE RANGE, THE RANGE MUST BE SECURED BY PROPERLY INSTALLED ANTI-TIP DEVICES. TO CHECK IF THE DEVICES ARE INSTALLED PROPERLY, SLIDE RANGE FORWARD, LOOK FOR ANTI-TIP BRACKET SECURELY ATTACHED TO FLOOR, AND SLIDE RANGE BACK SO REAR RANGE FOOT IS UNDER ANTI-TIP BRACKET.

• **CAUTION:** Do not store items of interest to children in cabinets above a range or on the back-guard of a range –children climbing on the range to reach items could be seriously injured.

• **Proper Installation –** The range, when installed, must be electrically grounded in accordance with local codes or, in the absence of local codes, with the *National Electrical Code, ANSI/NFPA 70*. Be sure the range is properly installed and grounded by a qualified technician.

• This range is equipped with a three-prong grounding plug for your protection against shock hazard and should be plugged directly into a properly grounded receptacle. Do not cut or remove the grounding prong from this plug.

• Disconnect the electrical supply before servicing the appliance.

• Never Use the Range for Warming or Heating the Room.

• Injuries may result from the misuse of appliance doors or drawers such as stepping, leaning, or sitting on the doors or drawers.

• Maintenance – Keep range area clear and free from combustible materials, gasoline, and other flammable vapors and liquids.

• Storage in or on the Range – Flammable materials should not be stored in an oven or near surface units.

• Top burner flame size should be adjusted so it does not extend beyond the edge of the cooking utensil.

For self-cleaning ranges –

• Before Self-Cleaning the Oven – Remove broiler pan and other utensils. Wipe off all excessive spillage before initiating the cleaning cycle.

SAVE THESE INSTRUCTIONS

PARTS AND FEATURES

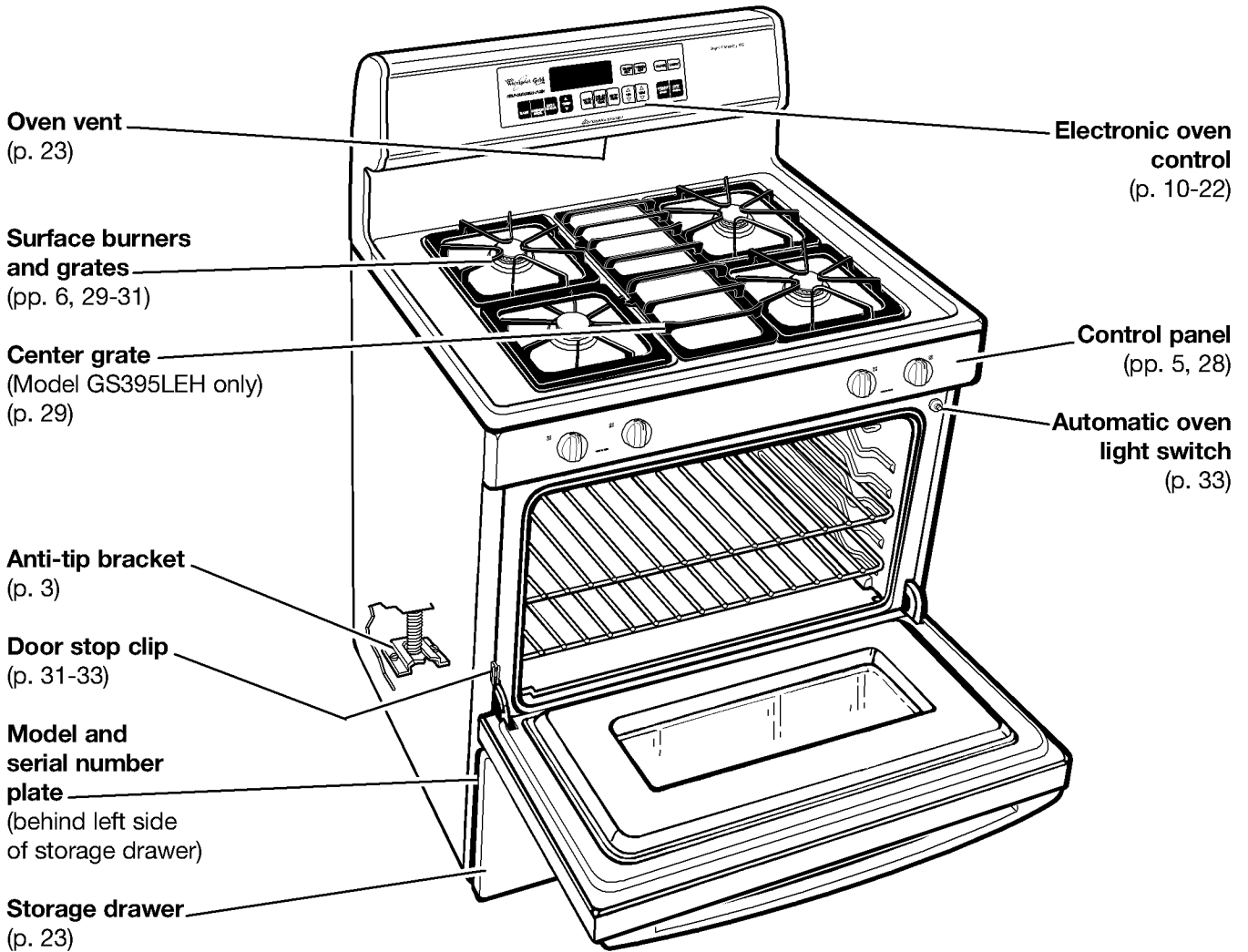

CONTROL PANEL

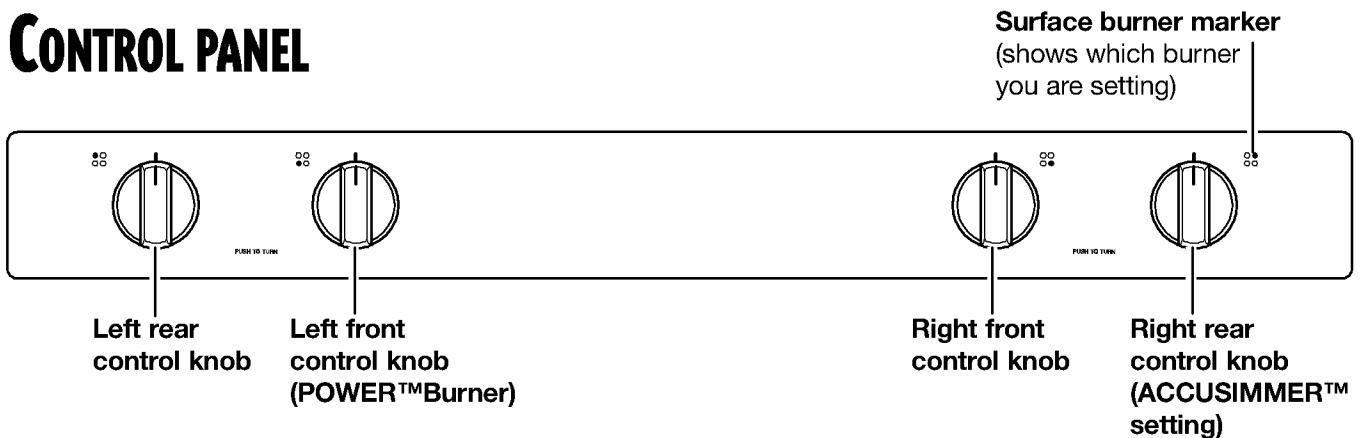

USING YOUR RANGE

USING THE SURFACE BURNERS

⚠ WARNING



Fire Hazard

Do not let the burner flame extend beyond the edge of the pan.

Turn off all controls when not cooking.

Failure to follow these instructions can result in death or fire.

Using the control knobs

Your range comes with electric ignitors. Electric ignitors automatically light the burners each time you turn the control knobs to LIGHT.

- Place a filled pan on the burner grate before turning on the surface burner. Do not operate a burner for extended periods of time without having cookware on the grate.
- Push in the control knob and turn it **counter-clockwise** to the LIGHT position. The clicking sound is the ignitor sparking. Make sure the burner has lit.

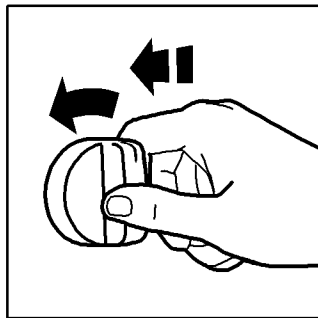

● To stop the clicking sound after the burner lights, turn the control knob to the cook setting you want. You can set the control knob

anywhere between HIGH and LOW.

NOTE: All four electric ignitors will click at the same time. However, the burner with the control knob turned to LIGHT is the one that will ignite.

Burner heat settings

Use the following chart as a guide.

SETTING	RECOMMENDED USE
LIGHT	● To light the burner.
POWER™ Burner (left front burner)	● To provide highest heat setting.
HIGH	● To start food cooking. ● To bring liquid to a boil.
Mid-range (between HIGH and LOW)	● To hold a boil. ● To fry chicken or pancakes. ● For gravy, pudding, and icing. ● To cook large amounts of vegetables.
LOW	● To keep food warm. ● To simmer.
ACCUSIMMER™ setting (right rear burner)	● To provide lowest simmer/heat setting. ● To melt chocolate or butter.

NOTE: Do not leave empty cookware, or cookware which has boiled dry, on a hot surface burner. The cookware could overheat, causing damage to the cookware or cooking product.

Using POWER Burner

POWER Burner is an adjustable setting for the left front burner which provides an ultra-high heat setting. It can be used to rapidly bring liquid to a boil and to cook large quantities of food.

Using ACCUSIMMER

ACCUSIMMER is an adjustable setting for the right rear burner. It allows more accurate simmer control at the lowest setting.

Easy ways to save energy

- To help shorten your cooking time, use the least amount of liquid possible.
- Preheat your pots and pans only when recommended and for the shortest time possible.
- Start your food on a higher heat setting, then turn the control to a lower setting to finish cooking.

USING THE SURFACE BURNERS (CONT.)

In case of a prolonged power failure

You can manually light surface burners. Hold a lit match near a burner and turn the control knob to the LIGHT position. After the burner lights, turn the control knob to the setting you want.

Home canning information

The large diameter of most water-bath or pressure canners combined with high heat settings for long periods of time can cause damage to the cooktop.

To protect your range:

- Center the canner over the surface burner. Do not extend more than 1 inch outside the burner area.
- Do not place your canner on two surface burners at the same time.
- Start with hot water, cover with a lid and bring to a boil; then reduce heat to maintain a boil or required pressure levels in a pressure canner.

- Refer to your canner manual for specific instructions.

For up-to-date information on canning, contact your local U.S. Government Agricultural Department Extension Office or companies who manufacture home canning products.

Using the right cookware makes a big difference

- The pan should have a flat bottom, straight sides, and a well-fitting lid.
- Choose medium to heavy gauge (thickness) cookware.
- The pan material (metal or glass) affects how quickly and evenly the pan heats.
- When using glass or ceramic cookware, check to make sure it is suitable for use on surface burners.
- To avoid tipping, make sure pots and pans are centered on the grates.

CHARACTERISTICS OF COOKWARE MATERIALS

The pan material affects how fast heat transfers from the surface cooking area through the pan material and how evenly heat spreads over the pan bottom. Choose pans that provide the best cooking results.

Aluminum	<ul style="list-style-type: none"> ● Heats quickly and evenly. ● Use for all types of cooking. ● Medium or heavy thickness is best for most cooking. ● Used as a core or base in cookware to provide even heating.
Cast iron	<ul style="list-style-type: none"> ● Heats slowly and evenly. ● Good for browning and frying. ● Maintains heat for slow cooking. ● Can be coated with porcelain enamel.
Ceramic or ceramic glass	<ul style="list-style-type: none"> ● Heats slowly and unevenly. ● Use on low to medium settings. ● Follow manufacturer's instructions.
Copper	<ul style="list-style-type: none"> ● Heats very quickly and evenly. ● Used as a core or base in cookware to provide even heating.
Earthenware	<ul style="list-style-type: none"> ● Can be used for cooktop cooking if recommended by the manufacturer. ● Use on low settings.
Porcelain enamel-on-steel or enamel-on-cast iron	<ul style="list-style-type: none"> ● See cast iron and stainless steel.
Stainless steel	<ul style="list-style-type: none"> ● Heats quickly but unevenly. ● A core or base of aluminum or copper on the cookware provides even heating. ● Can be coated with porcelain enamel.

USING THE OVEN

Positioning racks and pans

Place the oven racks where you need them before turning on the oven.

- To move a rack, pull it out to the stop position, raise the front edge and lift it out.
- Be sure the rack(s) is level.
- Use pot holders or oven mitts to protect your hands if rack(s) must be moved while the oven is hot.
- For best performance, cook on one rack. Place the rack so the top of the food will be centered in the oven.
- When cooking with two racks, arrange the racks on the 2nd and 4th rack guides. Two sheets of cookies may be baked if sheets are switched at approximately three quarters of the total bake time. Increase baking time, if necessary.
- For best results allow 2 inches of space around each pan and between pans and oven walls.

Extra oven rack position (roasting rack)

Use this rack position when roasting food too large to be placed on the first rack position.

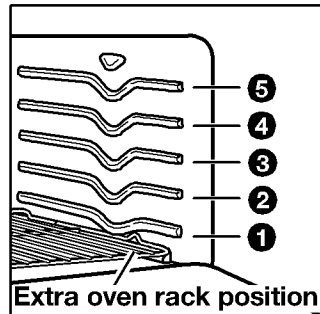

Extra oven rack position

For proper roasting, follow these guidelines:

- To avoid spillage, remove food before pulling out the rack.
- Tilt the rack up at the front before pulling it over the door.

- Use an adequate amount of liquid in the pan (meat juices or water) so your food does not get overdone.

Where to place pans:

WHEN YOU HAVE	PLACE
1 pan	In center of the oven rack.
2 pans	Side by side or slightly staggered.
3 or 4 pans	In opposite corners on each oven rack. Stagger pans so no pan is directly over another.

Rack placement for specific foods:

FOOD	RACK POSITION
Frozen pies, large roasts, turkeys, angel food cakes	1st or 2nd rack guide from bottom
Bundt cakes, most quick breads, yeast breads, casseroles, meats	2nd rack guide from bottom
Cookies, biscuits, muffins, cakes, nonfrozen pies	2nd or 3rd rack guide from bottom

NOTE: For information on where to place your rack when broiling, see “Broiling guidelines” later in this section.

USING ALUMINUM FOIL

- Do not line the oven bottom with any type of foil, liners, or cookware. Permanent damage will occur to the oven bottom finish.

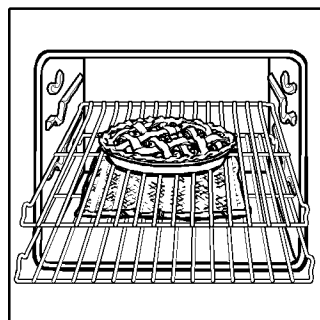

- Do not block the oven bottom vents.

- Do not cover the entire rack with aluminum foil. Doing so will reduce air circulation and overall oven performance.
- To catch spillovers from pies or casseroles place foil on the oven rack below. Foil should be turned up at edges and be at least 1 inch larger than dish.
- Place tent-shaped foil loosely over meat or poultry to slow down surface browning for long term roasting. Remove foil for the last 30 minutes.
- Use narrow strips of foil to shield piecrust edges if browning too quickly.

BAKEWARE CHOICES

Baking performance is affected by the type of bakeware used. Use the bakeware size recommended in the recipe.

BAKEWARE TYPE	BEST USED FOR	GUIDELINES
Light colored aluminum	<ul style="list-style-type: none"> • Light golden crusts • Even browning 	<ul style="list-style-type: none"> • Use temperature and time recommended in recipe.
Dark aluminum and other bakeware with dark, dull, and/or non-stick finish	<ul style="list-style-type: none"> • Brown, crisp crusts 	<ul style="list-style-type: none"> • May reduce baking temperature 25°F. • Use suggested baking time. • Use temperature and time recommended in recipe for pies, breads, and casseroles. • Place rack in center of oven.
Ovenproof glassware, ceramic glass, or ceramic	<ul style="list-style-type: none"> • Brown, crisp crusts 	<ul style="list-style-type: none"> • May reduce baking temperature 25°F.
Insulated cookie sheets or baking pans	<ul style="list-style-type: none"> • Little or no bottom browning 	<ul style="list-style-type: none"> • Place in the bottom third of oven. • May need to increase baking time.
Stainless steel	<ul style="list-style-type: none"> • Light, golden crusts • Uneven browning 	<ul style="list-style-type: none"> • May need to increase baking time.
Stoneware	<ul style="list-style-type: none"> • Crisp crusts 	<ul style="list-style-type: none"> • Follow manufacturer's instructions.

THE ELECTRONIC OVEN CONTROL

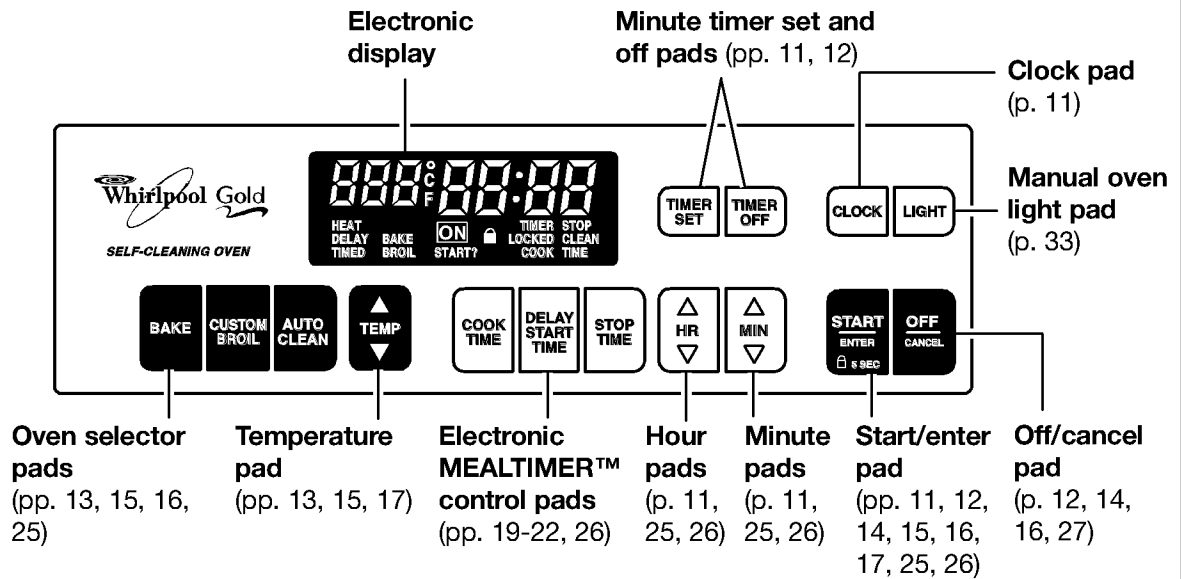

Display/clock

- When you first plug in the range, everything on the display will light up for 1 to 2 seconds, then a time of day and “PF” will appear on the temperature display. Press OFF/CANCEL to clear “PF” from the display. If, after you set the clock (see “Setting the clock” later in this section), “PF” again appears on the display, your electricity was off for a while. Reset the clock, if needed.
- When you are not using the oven, the control is an accurate clock.
- When you are using the oven or minute timer, the display will show times, temperature settings, and what command pads have been pressed.
- When showing the time of day, the display will show the hour and minutes.
- When you are using the minute timer, the display will show minutes and seconds in the following sequence:
 - For settings from 1-59 minutes, the display will count down each second.
 - For settings one hour or over, the display will count down each minute.
- When you are using cook time and/or stop time, the display will show hours and minutes or minutes and seconds.



Using the control lock

The control lock lets you shut down the control panel command pads. The control lock comes in handy when you want to prevent others from using the oven.

NOTES:

- You can only use the control lock when the oven is not in use or the control has not been set.
- Set the control lock when cleaning the control panel to prevent yourself from accidentally turning on the oven.
- The control lock will stay on even after a power failure.

To lock the control panel:

Press and hold START/ENTER for 5 seconds.



You will hear a single tone and “Loc” and  will appear on the temperature display. When the control is locked, “START?” will appear on the display and 3 tones will sound if you press any command pad other than clock or timer set.







To unlock the control panel:

Press and hold START/ENTER for 5 seconds.









You will hear 3 tones followed by a single tone. “Loc” and  will disappear from the temperature display.

SETTING THE CLOCK

<p>1. Press CLOCK.</p>	<p>PRESS</p>	<p>YOU SEE</p>
		
<p>2. Set the time. Press the “up” (▲) or “down” (▼) pad(s) until the correct time shows on the display.</p>	<p>PRESS</p>	<p>YOU SEE</p>
		 <p>(example for 5:30)</p>
<p>3. Start the clock. NOTE: If you do not want the clock time displayed, press and hold CLOCK for 5 seconds. To display the clock time again, press and hold CLOCK for 5 seconds. You should not have to reset the time.</p>	<p>PRESS</p>	<p>YOU SEE</p>
		

USING THE ELECTRONIC MINUTE TIMER

The minute timer does not start or stop the oven. It works like a kitchen timer. It can be set in hours and minutes up to 12 hours, 59 minutes. The minute timer will display minutes and seconds for settings under 1 hour. You will hear four 1-second tones when the set time is up.

<p>1. Press TIMER SET.</p>	<p>PRESS</p>	<p>YOU SEE</p>
		
<p>2. Set the time. Press the “up” (▲) or “down” (▼) pad(s) until the correct time shows on the display.</p>	<p>PRESS</p>	<p>YOU SEE</p>
		 <p>(example for 10 minutes)</p>
<p>3. Start the minute timer. The minute timer will begin counting down immediately after the timer is started.</p>	<p>PRESS</p>	<p>YOU SEE</p>
		 <p>(display counts down)</p>

continued on next page

USING THE ELECTRONIC MINUTE TIMER (CONT.)

When the time is up:

You will hear four 1-second tones, then four 1-second reminder tones every minute until you press the timer off pad.

NOTE: To remove the reminder tones, press and hold **TIMER SET** for 5 seconds. To bring back the tones, follow the same step. You will see “OFF” when the tones are turned off and “on” when they are turned on.

YOU SEE



4. Turn off the minute timer.

PRESS



YOU SEE



(time of day)

To cancel the minute timer:

Press **TIMER OFF**.

PRESS



YOU SEE



(time of day)

STARTING/CANCELING A FUNCTION

After setting a function, you must press **START/ENTER** to start the function. If you do not press **START/ENTER** within 5 seconds of setting, “START?” will show on the display as a reminder.



OFF/CANCEL will cancel any function except the clock, timer, or control lock. When you press **OFF/CANCEL**, the display will show the time of day or, if the minute timer is also being used, the time remaining.



TONES

Tones tell you if a function is entered correctly or not. They also tell you when a cycle is completed.

To shut off all tones except the end-of-timer and error tones:

Press and hold **STOP TIME** for 5 seconds. A short tone will sound to tell you the tones have been changed. Repeat to turn the tones back on. You will see “oFF” for 3 seconds when the tones are turned off and “on” for 3 seconds when they are turned on.



To choose between high and low volume tones:

Press and hold **DELAY START TIME** for 5 seconds.

A short tone will sound to tell you the tones have been changed. Either “HI” or “LO” will appear on the time display for 3 seconds to show the volume you chose.



BAKING/ROASTING

IMPORTANT:

- Never try to light the oven burner during a power failure.
- Never place food on the oven door or oven bottom.

1. Place the racks where you need them. For more information, see “Positioning racks and pans” in “Using the Oven” earlier in this section.

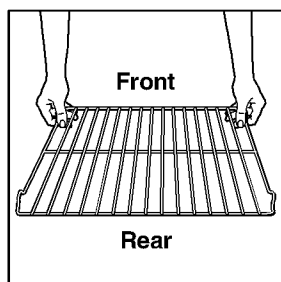

2. Choose the bake setting.

PRESS



YOU SEE



3. Set the temperature (optional).

Do this step if you want to set a temperature other than 350°F. Press ▲ to raise the temperature or ▼ to lower the temperature in 5°F amounts. Use these pads until the desired temperature shows on the small display.

PRESS



YOU SEE



(example for bake at 375°F)

4. When roasting, put your food in the oven. You do not have to preheat the oven when roasting, unless your recipe recommends it.

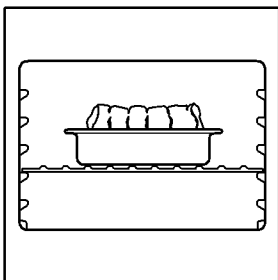

NOTE: The oven will cook normally even though the preheat conditioning timer is displayed.

Roasting meats and poultry

- For even cooking, place the meat on a rack in a shallow pan. This keeps the meat out of the drippings and allows the heat to circulate better.
- Use a meat thermometer for the most accurate doneness. Insert it so the tip is in the center of the largest muscle or thickest portion of the meat or poultry. Make sure the thermometer is not touching bone, fat, or the bottom of the pan.

continued on next page

BAKING/ROASTING (CONT.)

5. Press START/ENTER.

A preheat conditioning time counts down the approximate preheat time after the oven temperature has been set and START has been pressed. The oven control automatically sets preheating times based on the oven temperature you select:

- For 245°F and less, the preheating time is 4 minutes.
- For 250°F-445°F, the preheating time is 10 minutes.
- For above 450°F, the preheating time is 15 minutes.

As the preheat conditioning ends, the selected oven temperature replaces “PrE” on the display and the time of day reappears. You will hear a 1-second tone, indicating the oven is ready to use.

The ACCUBAKE® system electronically regulates the preheat time and temperature to maintain a precise temperature range for the best cooking results. The preheat and set temperatures may be different at the end of the countdown. This is normal.

NOTES:

- When the oven temperature is greater than 170°F, no preheating time will be shown on the display.
- You can change the temperature setting any time after pressing START/ENTER. You do not have to press START/ENTER again.
- The preheating time will not change if you reset the temperature before the countdown time ends.
- If you are baking/roasting while the minute timer is counting down, you can see the set baking/roasting temperature for 5 seconds by pressing BAKE.

PRESS



YOU SEE



(example for set temperature of 350°F)

YOU SEE



6. When baking, put your food in the oven after the preheat conditioning time ends. During baking/roasting, the oven burner will turn on and off to keep the oven temperature at the setting.

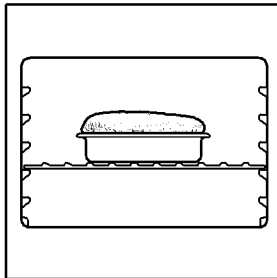

the preheat conditioning time ends. During baking/roasting, the oven burner will turn on and off to keep the oven temperature at the setting.

Saving energy

- To avoid loss of heat, open the oven door as little as possible.
- Use a timer to keep track of cooking time.
- Plan your meals for the most efficient use of the oven by cooking more than one food at a time, or baking while the oven is still hot after cooking a meal.

7. After cooking, turn off the oven.

PRESS



YOU SEE



(time of day)

ADJUSTING THE OVEN TEMPERATURE CONTROL

Although your new oven is properly adjusted to provide accurate temperatures, it may cook faster or slower than your old oven.

If you are not satisfied with the baking/roasting results, you can change the offset temperature by following the steps below.

NOTE: DO NOT measure the oven temperature with a thermometer. Opening the oven door will lower the oven temperature and give you an incorrect reading. Also, the thermometer temperature reading will change as your oven cycles.

1. Press and hold BAKE for 5 seconds.

The display will show the current offset temperature, for example “0,” if you have not already adjusted the temperature.

PRESS



YOU SEE



(factory setting of “0”)

2. Set the new offset temperature.

Press ▲ to raise the temperature or ▼ to lower the temperature in 10°F amounts. You can set the temperature change to as low as -30°F or as high as +30°F. A minus (-) sign will appear before the number when decreasing the temperature setting. The minus sign shows the oven will be cooler by the displayed amount. There is no sign in front of the number when increasing the temperature setting.

PRESS



YOU SEE



(example when making oven 10°F warmer)

3. Enter the adjustment.

NOTE: You must press START/ENTER or your changes will not be made.

PRESS



YOU SEE



(time of day)

To display temperatures in °C instead of °F:

Press and hold the custom broil pad for 5 seconds.

You will hear a short tone and the temperatures

displayed will switch to °C. To switch back to °F, repeat the instructions above. Whenever you switch, “°C” or “°F” will be displayed for 5 seconds.



How to determine the amount of adjustment needed

The chart at the right tells you how much to adjust the offset temperature to get the cooking results you want. You can figure out cooking results by the amount of browning, moistness, and rising times for baked foods.

TO COOK FOOD ...	ADJUST BY THIS NUMBER OF DEGREES (FAHRENHEIT)
A little more	+10
Moderately more	+20
Much more	+30
A little less	-10
Moderately less	-20
Much less	-30

BROILING

NOTE:

- Do not preheat when broiling unless your recipe recommends it.

- 1.** Place the rack where you need it in the oven. See “Broiling guidelines” later in this section.

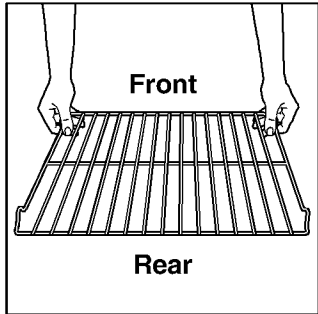

- 2.** Put your food on the broiler pan and place the pan in the center of the oven rack.

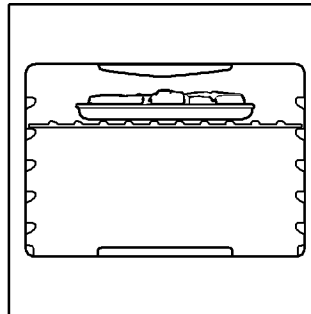

- 3.** Close the door.

- 4.** Press CUSTOM BROIL.

PRESS



YOU SEE



- 5.** Start the oven.

You can change the temperature setting any time before or after pressing START/ENTER. To change the setting, see “To custom broil at a lower temperature” later in this section. After changing the setting, you do not have to press START/ENTER again.

PRESS



YOU SEE



- 6.** After broiling, turn off the oven.

PRESS



YOU SEE



(time of day)

BROILING (CONT.)

To custom broil at a lower temperature:

- If your food is cooking too fast, press the ▼ temp pad until “325°F” shows on the small display.

PRESS



YOU SEE



(example shows broil at 325°F)

- If you want your food to broil slower from the start, press CUSTOM BROIL and press the ▼ temp pad so a temperature between 300°F and 525°F shows on the small display. Press START/ENTER.

PRESS



YOU SEE



(example shows broil at 400°F)

Lower temperature settings let the broil heating element cycle and slow cooking results. The lower the temperature, the slower the cooking.

NOTE: Fish and chicken are some foods that may cook better if you use lower broiling temperatures.



YOU SEE



Broiling guidelines

- Use only the broiler pan and grid provided. They are designed to drain extra juices from the cooking surface. This drainage helps prevent spatter and smoke.
- To make sure the juices drain well, do not cover the grid with foil.
- Trim excess fat to reduce spattering. Slit the fat on the edges to prevent curling.
- Use tongs to turn meat to avoid losing juices.
- Pull out oven rack to stop position before turning or removing food.
- After broiling, remove the pan from the oven when removing the food. Drippings will bake on the pan if left in the heated oven, making cleaning more difficult.
- For easier cleaning, line the bottom of the pan with aluminum foil. Clean the pan and grid as soon as possible after each use.

continued on next page

BROILING (CONT.)

Broiling guidelines (cont.)

Recommended rack positions are numbered from the bottom (1) to the top (5). For best results, place food 3 inches or more from broil burner.

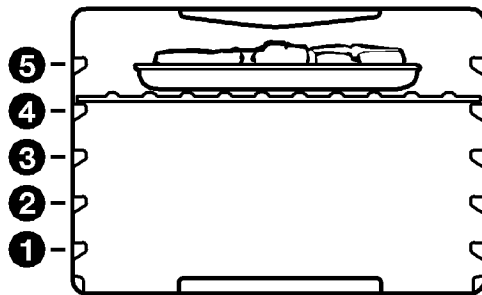

MEAT	RACK POSITION	APPROXIMATE TIME (MINUTES)	
		SIDE 1	SIDE 2
Steak, 1" thick	4		
medium rare		14-15	7-8
medium		15-16	8-9
well done		18-19	9-10
Ground Meat Patties, ¾" thick, well done	4	13-14	6-7
Pork Chops, 1" thick	4	21-22	10-11
Ham Slice, ½" thick, precooked	4	8-10	4-5
Frankfurters	4	6-7	3-4
Lamb Chops, 1" thick	4	15-17	8-9
Chicken			
bone-in pieces	3	18-20	18-20
boneless breasts	4	12-16	11-16
Fish	4		
fillets ¼-½" thick		8-10	4-5
steaks ¾-1" thick		15-18	7-9

Times are guidelines only and may need to be adjusted for individual tastes.

USING THE ELECTRONIC MEALTIMER™ CONTROL

The electronic MEALTIMER control will turn the oven on and off at times you set, even when you are not around.

Delayed time baking/roasting is ideal for foods that do not need a preheated oven, like meats and casseroles. **Do not use delayed time cooking for cakes, cookies, etc. – they will not rise properly.**

Before using the electronic MEALTIMER control, make sure the clock is set to the correct time of day. (See the “Setting the clock” section.)

⚠ WARNING

Food Poisoning Hazard

Do not let food sit in oven more than one hour before or after cooking.

Doing so can result in food poisoning or sickness.

To start baking/roasting now and stop automatically:

1. Place the oven rack(s) where you need them and put your food in the oven. To place your racks correctly, see “Positioning racks and pans” in “Using the Oven” earlier in this section.

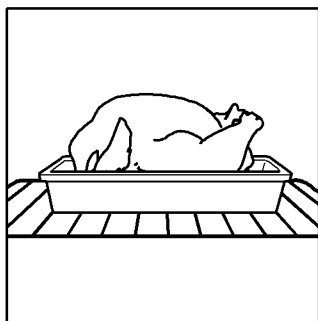

Place your food in the oven. To place your racks correctly, see “Positioning racks and pans” in “Using the Oven” earlier in this section.

2. Choose the bake setting.

PRESS



YOU SEE



3. Set the temperature (optional).

Do this step if you want to set a temperature other than 350°F. Press ▲ to raise the temperature or ▼ to lower the temperature in 5°F amounts. Use these pads until the temperature you want shows on the small display.

PRESS



YOU SEE



(example shows bake at 375°F)

4. Press COOK TIME.

PRESS



YOU SEE



USING THE ELECTRONIC MEALTIMER™ CONTROL (CONT.)

5. Set the cook time.

Press the “up” (▲) or “down” (▼) pad(s) until the correct time shows on the display.

PRESS



YOU SEE



(example shows 30-minute baking/roasting time)

6. Start the oven.

NOTES:

- You can change the temperature or time settings any time after pressing START/ENTER by repeating Steps 3 or 5. You do not have to press START/ENTER.
- The display will count down the baking/roasting time in hours and minutes (if cook time is more than 1 hour) or in minutes and seconds (if cook time is less than 1 hour).

PRESS



YOU SEE



(display counts down cook time)

7. When baking/roasting is done:

The oven will turn off by itself and beep 4 times. You will also hear four 1-second tones every minute until you press OFF/CANCEL.

NOTE: To remove the reminder tones, press and hold the cook time pad for 5 seconds. To bring back the tones, repeat this step. You will see “off” when the tones are turned off and “on” when they are turned on.

YOU SEE



8. Turn off the oven.

NOTE: You can do this step any time to cancel the MEALTIMER control setting.

PRESS



YOU SEE



(time of day)

USING THE ELECTRONIC MEALTIMER™ CONTROL (CONT.)

To delay start and stop automatically:

1. Place the oven rack(s) where you need them and

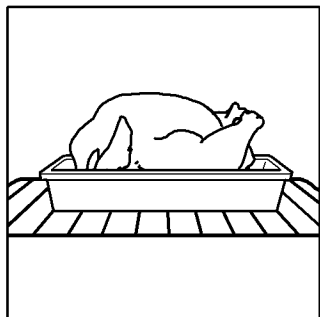

put your food in the oven. To place your racks correctly, see "Positioning racks and pans" in "Using the Oven", earlier in this section.

2. Choose the bake setting.

PRESS



YOU SEE



3. Set the temperature (optional).

Do this step if you want to set a temperature other than 350°F. Press ▲ to raise the temperature or ▼ to lower the temperature in 5°F amounts. Use these pads until the temperature you want shows on the small display.

PRESS



YOU SEE



(example shows bake at 375°F)

4. Press COOK TIME.

PRESS



YOU SEE



5. Set the cook time.

Press the "up" (▲) or "down" (▼) pad(s) until the correct time shows on the display.

PRESS



YOU SEE

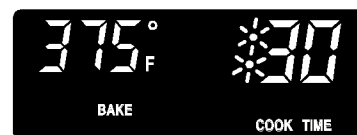

(example shows 30-minute baking/roasting time)

6. Press DELAY START TIME.

PRESS



YOU SEE



USING THE ELECTRONIC MEALTIMER™ CONTROL (CONT.)

7. Set the start time.

Press the “up” (▲) or “down” (▼) pad(s) until the correct time shows on the display.

The example at the right shows a chosen start time of 1:00. The oven will shut off by itself at 1:30 (the set start time plus the set cook time).

PRESS



YOU SEE



(example shows 1:00 start time)

8. Press START/ENTER.

NOTE: You can change the temperature or time settings any time after pressing START/ENTER by repeating Steps 2 through 7.

PRESS



YOU SEE



9. When the start time is reached:

You will hear a 1-second tone. The display will count down the baking/roasting time in hours and minutes (if the cook time is more than 1 hour) or in minutes and seconds (if the cook time is less than 1 hour).

YOU SEE



(display counts down cook time)

10. When baking/roasting is done:

The oven will turn off by itself and beep 4 times. You will also hear four 1-second tones every minute until you press OFF/CANCEL.

NOTE: To remove the reminder tones, press and hold COOK TIME for 5 seconds. To bring back the tones, repeat this step. You will see “oFF” when the tones are turned off and “on” when they are turned on.

YOU SEE



11. Turn off the oven.

NOTE: You can do this step any time to cancel the MEALTIMER control setting.

PRESS



YOU SEE



(time of day)

THE OVEN VENT

Hot air and moisture escape from the oven through a vent that is near the middle of the backguard. The vent lets air circulate properly. Be careful not to block the vent, or you will get poor baking/roasting results.

NOTE: Never store plastics, paper, or other items that could melt or burn near the oven vent, or any of the surface burners.

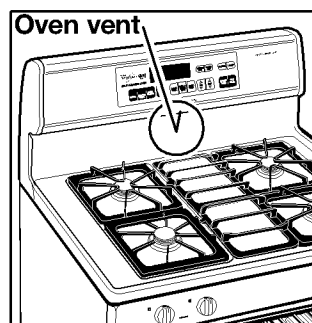

THE STORAGE DRAWER

Use the storage drawer to store cookware. You can remove the storage drawer to make it easier to clean under your range.

Removing the storage drawer:

1. Empty the drawer before you remove it. Pull the drawer straight out to the first stop. (The stops are small, round objects formed in the slide rail. They keep the drawer from sliding all the way out.) Then lift the front of the drawer and pull it out to the second stop.
2. Lift the back of the drawer slightly and slide it all the way out.

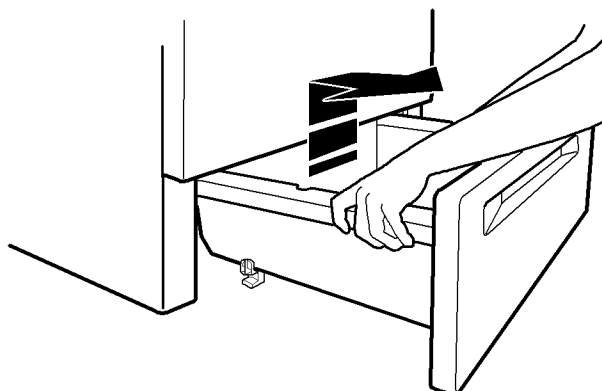

Replacing the storage drawer:

1. Position the drawer so that the lower drawer guides rest just inside the front frame lip.
2. Lift the front of the drawer and push it in until the metal stops on the drawer slide rails clear the upper drawer guides. Then slide the drawer closed.

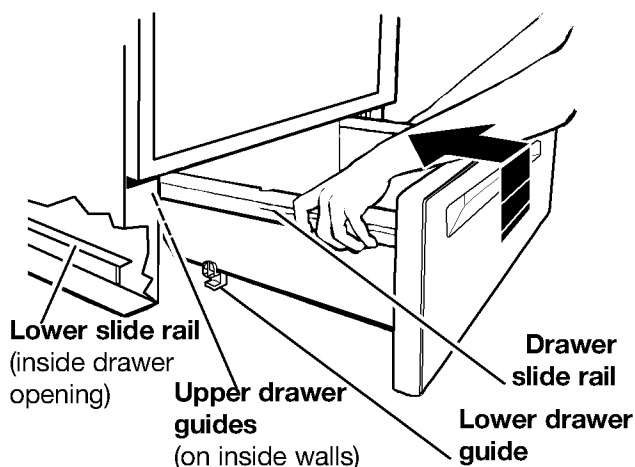

USING THE SELF-CLEANING CYCLE



!WARNING

Burn Hazard

Do not touch the oven during the Self-Cleaning cycle.
Keep children away from oven during Self-Cleaning cycle.
Do not use commercial oven cleaners in your oven.
Failure to follow these instructions can result in burns, or illness from inhaling dangerous fumes.

BEFORE YOU START

Before you start the Self-Cleaning cycle, make sure you:

NOTE: DO NOT clean, move, or bend the gasket. You may get poor cleaning, baking, and roasting.

- Hand-clean the areas shown. They do not get hot enough during the Self-Cleaning cycle for soil to burn away. Use hot water and detergent or a soapy, steel-wool pad for cleaning.
- Do not let water, cleaner, etc., enter slots on door and frame.
- Remove the broiler pan and grid and any cookware/bakeware being stored in the oven.
- Wipe out any loose soil or grease. This will help reduce smoke during the Self-Cleaning cycle.
- Wipe up food spills containing sugar as soon as possible after the oven cools down. When sugar is heated to a high temperature in the Self-Cleaning cycle, the high temperature can cause the sugar to burn and react with the porcelain. This can cause staining and etching, pitting, or faint white spots.
- Remove the oven racks from the oven if you want them to remain shiny. You can clean the oven racks in the Self-Cleaning cycle, but they will become harder to slide. (See the “Cleaning chart” in the “Caring for Your Range” section.) If you clean the racks in the Self-Cleaning cycle, place them on the 2nd and 4th rack guides. (The guides are counted from bottom to top.)
- Heat and odors are normal during the Self-Cleaning cycle. Keep the kitchen well ventilated by opening a window or by turning on a vent hood or other kitchen vent during the cycle.

IMPORTANT: The health of some birds is extremely sensitive to the fumes given off during the Self-Cleaning cycle. Move birds to another closed and well ventilated room.

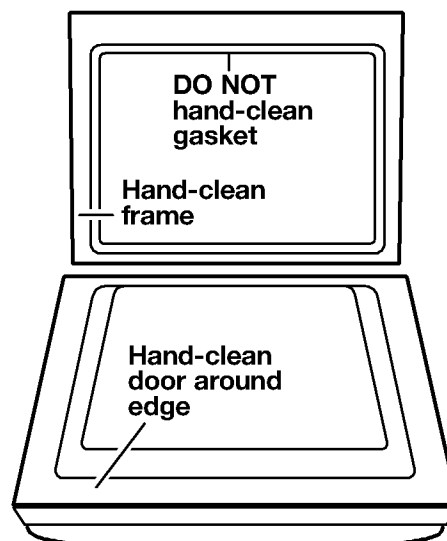

TIPS:

- Keep the kitchen well ventilated during the Self-Cleaning cycle to help get rid of heat, odors, and smoke.
- Clean the oven before it gets heavily soiled. Cleaning a very soiled oven takes longer and results in more smoke than usual.
- Do not block the vent during the Self-Cleaning cycle. Air must move freely for best cleaning results.
- Do not leave plastic utensils on the cooktop. They may melt.
- Remove any combustible items, such as paper napkins, from the storage drawer. This includes utensils with plastic handles that can become overheated and melt.
- Do not leave any foil in the oven during the Self-Cleaning cycle. Foil could burn or melt and damage the oven surface.
- The oven light will not work during the Self-Cleaning cycle.

SETTING THE CONTROLS

NOTE: Make sure the clock is set to the correct time of day. (See “Setting the clock” in the “Using Your Range” section.)

To start cleaning immediately:

1. Press AUTO CLEAN.

This will automatically set a 3½-hour Self-Cleaning cycle.

NOTE: There will be a 30-minute cool-down ½ hour before the cycle is over.

PRESS



YOU SEE



2. Set the cleaning time (optional).

If you want a Self-Cleaning cycle longer or shorter than 3½ hours, use the hour and minute pads to set the cleaning time you want. Press the “up” (▲) or “down” (▼) pad(s) until a time between 2½-4½ hours shows on the display.

- Use 2½ hours for light soil.
- Use 3½-4½ hours for average to heavy soil.

PRESS



YOU SEE



(example shows 4½-hour cleaning time)

3. Start the oven.

Make sure the door is closed all the way. If the door is open even a little, it will not lock. Press the door closed if needed. If the door is closed, it will lock as soon as you press START/ENTER.

PRESS



YOU SEE



4. After the Self-Cleaning cycle ends:

LOCKED goes off and the door unlocks.

YOU SEE



5. After the oven is cool, wipe off any residue or ash

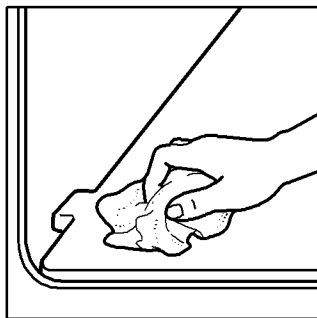

with a damp cloth or sponge. If needed, touch up spots with a mild abrasive cleanser or cleaning sponge.

continued on next page

SETTING THE CONTROLS (CONT.)

To delay the start using delay start time:

1. Press AUTO CLEAN.

This will automatically set a 3½-hour Self-Cleaning cycle.

NOTE: There will be a 30-minute cool-down ½ hour before the cycle is over.

PRESS



YOU SEE



2. Set the cleaning time (optional).

If you want a Self-Cleaning cycle longer or shorter than 3½ hours, use the Hour and Minute pads to set the cleaning time you want. Press the “up” (▲) or “down” (▼) pad(s) until a time between 2½-4½ hours shows on the display.

- Use 2½ hours for light soil.
- Use 3½-4½ hours for average to heavy soil.

PRESS



YOU SEE



(example for 4½-hour cycle)

3. Press DELAY START TIME.

PRESS



YOU SEE



4. Set the start time.

Press the “up” (▲) or “down” (▼) pad(s) until the correct time shows on the display. The oven will automatically come up with the stop time by adding the set cleaning time to the set start time.

PRESS

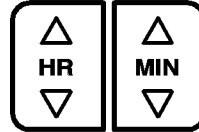

YOU SEE



(example for 2:30 start time)

5. Press START/ENTER.

The door will lock as soon as you press START/ENTER.

PRESS



YOU SEE

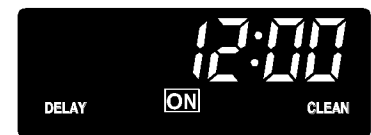

6. After the Self-Cleaning cycle starts:

YOU SEE



7. After the Self-Cleaning cycle ends:

LOCKED goes off and the door unlocks.

NOTE: The stop time will be the start time plus the cleaning time.

YOU SEE



SETTING THE CONTROLS (CONT.)

8. After the oven cools to room temperature, wipe off any residue or ash with a damp cloth or sponge. If needed, touch up spots with a mild abrasive cleanser or cleaning sponge.

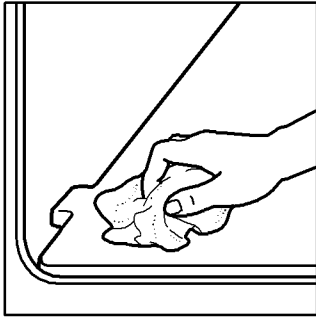

To stop the self-cleaning cycle at any time:

If the oven temperature is too high for baking/roasting when you press OFF/CANCEL, “cln,” TIMED, ON, “cool,” and LOCKED will appear on the display until the oven cools.

PRESS



YOU SEE



HOW THE CYCLE WORKS

The Self-Cleaning cycle uses very high heat to burn away soil and grease. During the cycle, the oven gets much hotter than it does for normal baking or broiling. This high heat breaks up the soil or grease and burns it away.

Your oven is automatically preset for a 3½-hour Self-Cleaning cycle.

The graph at the right shows you what happens in a 3½-hour Self-Cleaning cycle. Notice that the heating stops ½ hour before the 3½-hour setting is up.

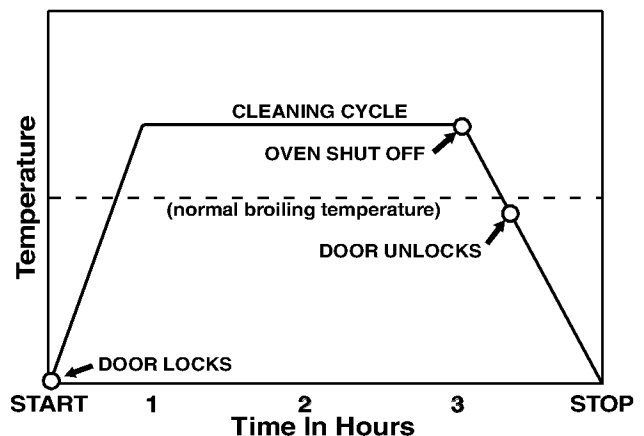

CARING FOR YOUR RANGE

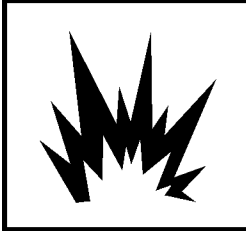

⚠️ WARNING

Explosion Hazard

Do not store flammable materials such as gasoline near this appliance. Doing so can result in death, explosion, or fire.

CLEANING CHART

Before cleaning, always make sure all controls are off and the range is cool. Refer to instructions on all cleaning products before using them to clean your range.

PART	CLEANING METHOD	SPECIAL INSTRUCTIONS
Control Knobs	<ul style="list-style-type: none"> • Soap and water • Dishwasher 	<ul style="list-style-type: none"> • DO NOT use steel wool or abrasive cleaners. • Pull knobs straight away from control panel. • Wash, rinse and dry with soft cloth.
Control Panel	<ul style="list-style-type: none"> • Soap and water • Spray glass cleaner 	<ul style="list-style-type: none"> • Wash, rinse and dry with soft cloth. • Apply spray cleaner to paper towel; do not spray directly on panel.
Exterior Surfaces* (excluding control panel and oven door glass)	<ul style="list-style-type: none"> • Soap and water • Mild liquid cleaner • Spray glass cleaner • Non-abrasive plastic scrubbing pad 	<ul style="list-style-type: none"> • DO NOT use abrasive or harsh cleaners like chlorine bleach, ammonia or oven cleaners. • Wash, rinse and dry with soft cloth. • Gently clean around the model and serial plate, too much scrubbing could remove the numbers. • NOTE: To avoid product damage, do not remove the cooktop.
Stainless steel surfaces (Model GS395LEH)		<ul style="list-style-type: none"> • DO NOT use steel wool or soap-filled scouring pads. • Rub in the direction of the grain line to avoid marring the surface. • Always wipe dry to avoid water marks. • If commercial cleaners are used, follow label directions. If product contains chlorine (bleach), wipe thoroughly with clean water and dry with a soft lint-free cloth. Chlorine is a corrosive substance.

*When the cooktop is cool, remove all spills and clean. Food spills containing acids, such as vinegar and tomato, may affect the finish.

CLEANING CHART (CONT.)

PART	CLEANING METHOD	SPECIAL INSTRUCTIONS
<p>Stainless steel surfaces (Model GS395LEH) (cont.)</p> <ul style="list-style-type: none"> • Routine cleaning and fingerprints • Stubborn stains and baked-on residue • Hard water spots 	<ul style="list-style-type: none"> • Liquid detergent/soap and water, or all-purpose cleaner • Mildly abrasive cleanser or stainless-steel cleaners • Vinegar 	<ul style="list-style-type: none"> • Wipe with damp cloth or sponge, then wipe with clean water and dry. • To avoid marring the surface, rub in the direction of grain lines with a damp cloth or sponge and cleanser. Wipe thoroughly with clean water. Repeat if necessary. • Swab or wipe with cloth. Wipe with clean water and dry.
<p>Surface burner grates and caps*</p> <ul style="list-style-type: none"> • Light to moderate soil • Heavy burned on soils 	<ul style="list-style-type: none"> • Soap and water • Non-abrasive plastic scrubbing pad • Dishwasher • Non-abrasive plastic scrubbing pad • Mild abrasive powdered cleanser and water 	<ul style="list-style-type: none"> • Clean as soon as they become dirty. • Wash, rinse and dry well. • Grates only (not caps). • Repeat steps of cleaning process (with items at left) as needed, until soil is completely removed. • Rinse thoroughly and dry. • NOTE: Do not reassemble caps on burners while wet.
<p>Surface burners</p>		<ul style="list-style-type: none"> • See the “Sealed surface burner” section in the “Caring for your range” section.
<p>Oven door glass</p>	<ul style="list-style-type: none"> • Soap and water • Non-abrasive plastic scrubbing pad • Spray glass cleaner 	<ul style="list-style-type: none"> • Wash, rinse and dry with soft cloth. • Wipe with paper towel.
<p>Oven cavity</p> <ul style="list-style-type: none"> • Food spills containing sugar and/or milk • All other spills 	<ul style="list-style-type: none"> • Soap and water • Self-cleaning cycle 	<ul style="list-style-type: none"> • When oven cools, wash, rinse and dry with soft cloth. See the “Using the self-cleaning cycle” section. • See the “Using the self-cleaning cycle” section.
<p>Oven racks</p>	<ul style="list-style-type: none"> • Soap and water • Steel wool pad • Self-cleaning cycle 	<ul style="list-style-type: none"> • Wash, rinse and dry. • Place on 2nd and 4th rack guides. Racks will discolor and become harder to slide. After cleaning, apply vegetable oil to rack guides for easier sliding.
<p>Broiler pan and grid</p>	<ul style="list-style-type: none"> • Soap and water • Steel wool pad • Dishwasher • Solution of ½ cup ammonia to 1 gallon water • Mild abrasive cleanser or commercial oven cleaner 	<ul style="list-style-type: none"> • Wash, rinse and dry. • Soak for 20 minutes, then scrub with plastic scrubbing pad. • DO NOT clean the pan and grid in the self-cleaning cycle.

SEALED SURFACE BURNERS AND COOKTOP

Cleaning the surface burners

- You should routinely remove and clean the burner cap. Always clean the burner cap after a spill-over. Keeping the burner cap clean prevents improper ignition and an uneven flame.
- For the proper flow of gas and ignition of the burner, **do not allow spills, food, cleaning agents, or any other material to enter the gas tube opening or burner ports.**
- Gas must flow freely through the gas tube opening for the burner to light properly. You must keep this area free of any soil and protect it from boilovers or spillovers. **Always** keep the burner cap in place whenever a surface burner is in use.
- Let the cooktop cool before cleaning.
- Do not use oven cleaners, bleach, or rust removers.
- Do not obstruct the flow of combustion and ventilation air.
- Be careful not to allow moisture to collect in the burner control knob areas. Moisture can cause the ignitor switches to fail.

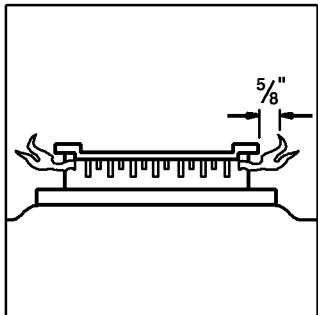
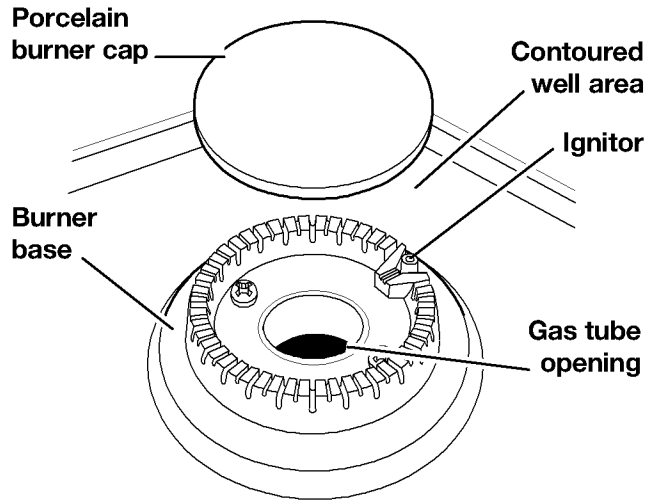

Occasionally check the burner flames for proper size and shape as shown. A good flame is blue in color. If the flames are uneven, you may need to clean the burner ports.

SEALED SURFACE BURNERS AND COOKTOP (CONT.)

To clean the burners:

1. Pull the burner cap straight up from the burner base.
2. Clean the burner cap with warm, soapy water and a sponge. You can also clean it with a mildly abrasive scrubbing pad or cleanser. Do not clean the burner cap in a dishwasher or self-cleaning oven.
3. If the gas tube opening has become soiled or clogged, use a cotton swab or a soft cloth to clean the area.
4. If the ports are clogged, clean them with a straight pin. Do not enlarge or distort the port. Do not use a wooden toothpick. If the burner needs to be adjusted, call a qualified technician for service.

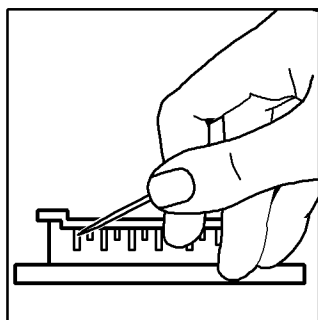

5. After cleaning the gas tube opening and ports, replace the burner cap. To replace the burner cap, make sure the alignment pins on the cap are properly aligned with the burner base.

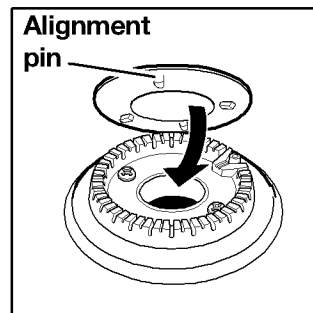

6. Turn on the burner to see if it will light. If the burner does not light after you have cleaned it, recheck cap alignment or contact a designated service technician. Do not service the sealed burner yourself.

REMOVING THE OVEN DOOR

For normal use of your range, you do not need to remove the door. However, if you find it necessary to remove the door, follow the instructions in this section.

NOTE: The oven door is heavy.

Before removing the door:

1. Use a putty knife or screwdriver and insert it at the bottom corner of the door stop clip.
2. Pry door stop clip free and remove from front frame hinge slot. Take care not to scratch porcelain.
3. Repeat procedure for other door stop clip.

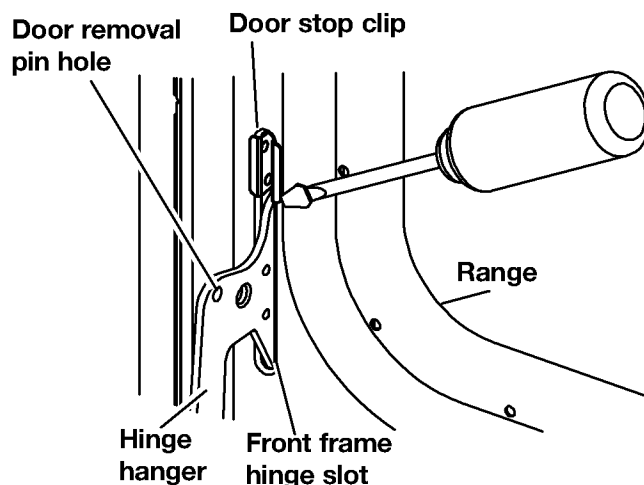

REMOVING THE OVEN DOOR (CONT.)

To remove:

1. Open the oven door. Insert door removal pins, included with your range, into both hinge hangers. **Do not remove the pins while the door is removed from the range.**

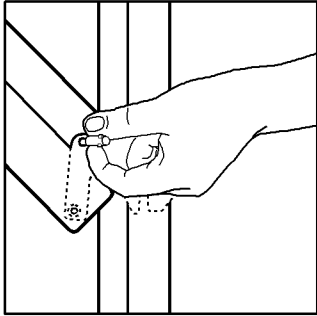

2. Carefully close the door until it rests against the door removal pins.

3. Grasp the door on the sides with your fingers on the front of the door and your thumbs on the inside surface.

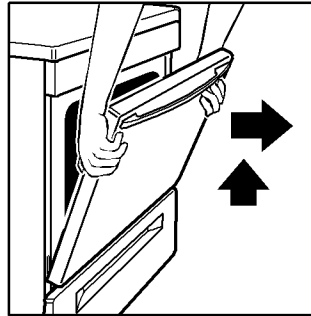

4. Pull door straight up, then toward you. Hinge hangers will slide out of front frame hinge slot.

To replace:

NOTE: The door removal pins you inserted must still be in both door hinges.

1. Grasp the door on the sides with your fingers on the front of the door and your thumbs on the inside surface.

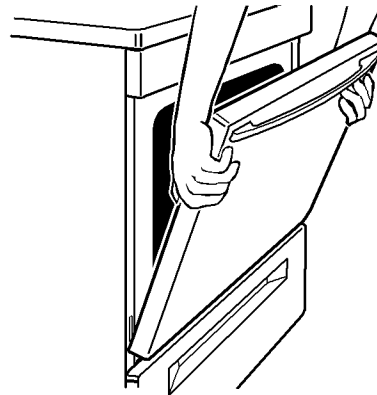

REMOVING THE OVEN DOOR (CONT.)

2. Hold oven door so that the top edge of each hinge hanger is horizontal. Insert hinge hangers into the front frame hinge slots.

3. Rotate top of door toward range. Slide hinge hangers down onto front frame support pins.

NOTE: Make sure the hinge hangers are fully seated and engaged on the support pins.

4. Insert the door stop clip with the angular surface at the top of the frame hinge slot, then push in the bottom of the clip until flanges are flush with the front frame.

5. Open the door completely and remove the door removal pins. Save door removal pins for future use.

6. Close the door.

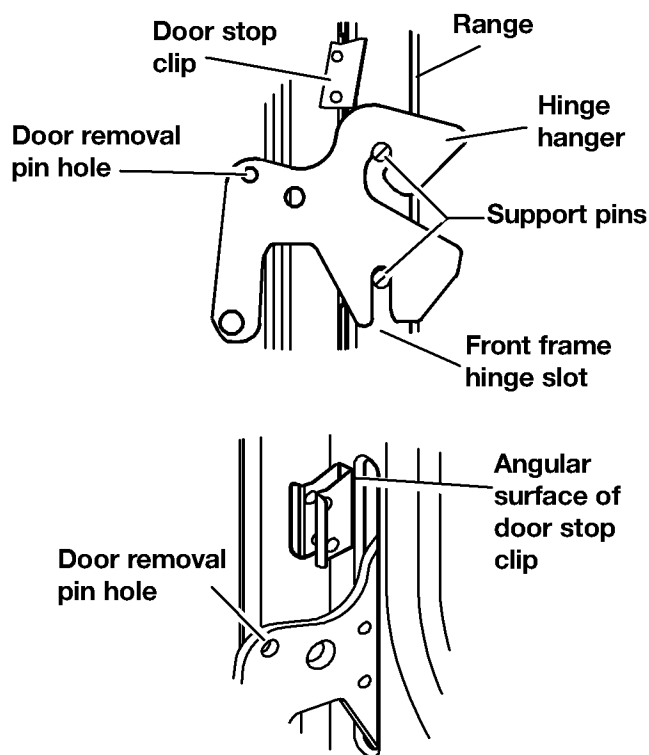

THE OVEN LIGHT

The oven light will come on when you open the oven door.

To turn the light on or off when the oven door is closed:

- Press the oven light pad.



To replace the oven light:

1. Unplug range or disconnect power.
2. Remove the glass bulb cover in the back of the oven by turning it counterclockwise.

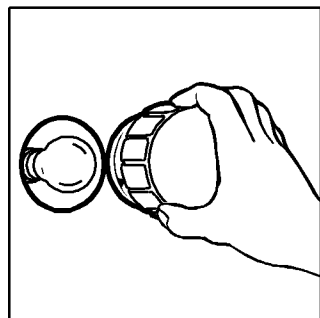

3. Remove the light bulb from its socket. Replace the bulb with a 40-watt appliance bulb.

4. Replace the light bulb cover by turning it clockwise.

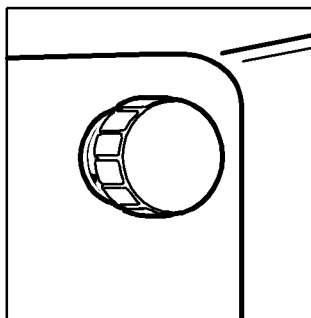

5. Plug in range or reconnect power.

NOTE: The oven light will not work during the Self-Cleaning cycle.

TROUBLESHOOTING

Most cooking problems often are caused by little things you can find and fix without tools of any kind. Check the lists below and on the next page before calling for assistance or service. If you still need help, see “Requesting Assistance or Service” on page 36.

RANGE DOES NOT WORK

PROBLEM	CAUSE
Nothing works	<ul style="list-style-type: none">● The range is not plugged into a properly grounded outlet (120v polarized).● The range is not properly connected to the gas supply. Contact a designated service technician to reconnect the range to the gas supply. (See the Installation Instructions.)● You have blown a household fuse or tripped a circuit breaker.

OVEN/BROILER BURNER

PROBLEM	CAUSE
The oven does not work	<ul style="list-style-type: none">● You have not set the electronic control correctly. Refer to setting the electronic oven control section. (See pages 10 to 22.)● You have set a delayed start time. Wait for the start time to be reached or cancel and reset the control.● The main or regulator gas shutoff valve is in the off position. (See the Installation Instructions.)
The burner fails to light	<ul style="list-style-type: none">● The ignitor is broken. Contact a designated service technician to replace it.● You have blown a household fuse or tripped a circuit breaker.
The burner flames lift away from the ports, are yellow, or are noisy	<ul style="list-style-type: none">● The air/gas mixture is incorrect. Contact a designated service technician to check the air/gas mixture or see the Installation Instructions.

SURFACE BURNERS

PROBLEM	CAUSE
The burner fails to light	<ul style="list-style-type: none">● The control knob is not set correctly. Push in the control knobs before turning them. Make sure the control knob is turned to the Light position. (See page 6.)● You have blown a household fuse or tripped a circuit breaker.● The burner ports may be clogged. Clean them with a straight pin. (See page 31.)
The burner flames are uneven	<ul style="list-style-type: none">● The burner ports may be clogged. Clean them with a straight pin. (See page 31.)● The burner caps may not be positioned properly. (See page 31.)
The burner flames lift off the ports, are yellow, or are noisy when turned off	<ul style="list-style-type: none">● The burner needs cleaning. (See pages 30 and 31.)● The air/gas mixture is incorrect. Contact a designated service technician to check the air/gas mixture or see the Installation Instructions.
The burner makes a popping noise when on	<ul style="list-style-type: none">● The burner is wet from washing. Let it dry.

WHEN SELF-CLEANING YOUR OVEN

PROBLEM	CAUSE
The Self-Cleaning cycle will not work	<ul style="list-style-type: none"> You did not press START/ENTER. You have set a delayed start time. Wait for the start time to be reached or cancel and reset the control.

COOKING RESULTS

PROBLEM	SOLUTION
Cookware not level on cooktop (Check to see if liquids are level in cookware)	<ul style="list-style-type: none"> Level the range. (See the Installation Instructions.) Use cookware with a flat bottom.
Excessive heat on cooktop in areas around cookware	<ul style="list-style-type: none"> Choose cookware the same size or slightly larger than the burner flame.
The oven temperature seems too low or too high	<ul style="list-style-type: none"> Adjust the oven temperature control. (See “Adjusting the oven temperature control” section.)
Slow baking or roasting	<ul style="list-style-type: none"> Increase baking or roasting time. Increase temperature 25°F. Preheat oven to selected temperature before placing food in when preheating is recommended. Choose bakeware that will allow 2 inches of air space around all sides. Open oven door to check food when timer signals shortest time suggested in recipe. Oven peeking can make cooking times longer.
Baked items too brown on bottom	<ul style="list-style-type: none"> Preheat oven to selected temperature before placing food in oven. Choose bakeware that will allow 2 inches of air space around all sides. Position rack higher in oven. Decrease oven temperature 15° to 25°F.
Unevenly baked items	<ul style="list-style-type: none"> Level the range. Bake in center of oven with 2 inches of space around each pan. Check to make sure batter is level in pan.
Crust edge browns before pie is done	<ul style="list-style-type: none"> Shield edge with foil.

DISPLAY MESSAGES

PROBLEM	CAUSE
The display is showing “PF”	<ul style="list-style-type: none"> There has been a power failure. Press OFF/CANCEL to clear the display, then reset the clock. (See page 11.)
“F” followed by a number shows on the display	<ul style="list-style-type: none"> Press OFF/CANCEL to clear the display. If an “F” code appears again, call for service. (See “If You Need Assistance or Service” on page 36.)

If none of these items are causing your problem, see “Requesting Assistance or Service” on page 36.

REQUESTING ASSISTANCE OR SERVICE

To avoid unnecessary service calls, please check the “Troubleshooting” section. It may save you the cost of a service call. If you still need help, follow the instructions below.

IF YOU NEED ASSISTANCE OR SERVICE

Call the Whirlpool Consumer Assistance



Center toll free at 1-800-253-1301. Our consultants are available to assist you.

When calling:

Please know the purchase date, and the complete model and serial number of your appliance (see the “A Note to You” section). This information will help Whirlpool better respond to your request.

Our consultants provide assistance with:

- Features and specifications on our full line of appliances
- Installation information
- Use and maintenance procedures

- Accessory and repair parts sales
- Specialized customer assistance (Spanish speaking, hearing impaired, limited vision, etc.)
- Referrals to local dealers, service companies, and repair parts distributors

Whirlpool designated service technicians are trained to fulfill the product warranty and provide after-warranty service, anywhere in the United States.

To locate the Whirlpool designated service company in your area, you can also look in your telephone directory Yellow Pages.

IF YOU NEED REPLACEMENT PARTS

If you need to order replacement parts, we recommend that you only use FSP® factory specified parts. FSP replacement parts will fit right and work right, because they are made to the same exacting specifications used to build every new WHIRLPOOL® appliance.

To locate FSP replacement parts in your area, call our Consumer Assistance Center telephone number or your nearest designated service center.

FOR FURTHER ASSISTANCE

If you need further assistance, you can write to Whirlpool with any questions or concerns at:

Whirlpool Brand Home Appliances
Consumer Assistance Center
c/o Correspondence Dept.
2000 North M-63
Benton Harbor, MI 49022-2692

Please include a daytime phone number in your correspondence.

INDEX

TOPIC	PAGE	TOPIC	PAGE
ANTI-TIP BRACKET	3	FEATURES	5
ASSISTANCE	36	MEALTIMER™ CONTROL	
BAKING		Delay start	21
ACCUBAKE® system	14	Starting now	19
Aluminum foil	9	MODEL AND SERIAL NUMBER	2
Bakeware	9	OVEN DOOR	31, 32, 33
Pans	8	OVEN LIGHT	33
Preheat conditioning	14	OVEN TEMPERATURE	
Racks	8	Adjusting	15
Setting cycle.....	13	Setting	13, 16
Tips.....	14	OVEN VENT	23
BROILING		PANS.....	8
Grid.....	17	PARTS	5
Guidelines	17, 18	RACKS	8
Pan	16, 17	ROASTING	
Rack positions	18	Pans	8
Setting cycle.....	16	Racks	8
CLEANING		Setting cycle.....	13
Broiler pan and grid	29	Tips.....	14
Control knobs.....	28	SAFETY	3, 4
Control panel	28	SELF-CLEANING CYCLE	
Exterior surfaces	28	Before you start	24
Oven cavity	29	Delay start	26
Oven door glass	29	How the cycle works	27
Oven racks	29	Setting the controls	25
Self-cleaning cycle.....	24	Tips.....	24
Stainless steel surfaces	28, 29	Starting immediately	25
Surface burners	29, 30, 31	Stopping the cycle	27
Surface burner grates and caps	29	SERVICE	36
CONTROL PANEL		STORAGE DRAWER	23
Burner heat settings.....	6	SURFACE BURNERS	
Celsius/fahrenheit.....	15	ACCUSIMMER™ setting	6
Control knobs.....	6	Control knobs.....	6
Surface burner markers	5	Control setting guide	6
COOKWARE		POWER™ Burner	6
Canning	7	Power failure	7
Materials.....	7	Surface burner markers	5
Tips.....	7	Tips.....	6
ELECTRONIC OVEN CONTROL		TROUBLESHOOTING	34, 35
Canceling	12	WARRANTY	40
Clock	11		
Control lock	10		
Display/clock	10		
Minute timer	11		
Starting.....	12		
Tones	12		

WARRANTY

WHIRLPOOL® Gas Range

LENGTH OF WARRANTY	WHIRLPOOL CORPORATION WILL PAY FOR
FULL ONE-YEAR WARRANTY FROM DATE OF PURCHASE	FSP® replacement parts and repair labor to correct defects in materials or workmanship. Service must be provided by a Whirlpool designated service company.
WHIRLPOOL CORPORATION WILL NOT PAY FOR	
<p>A. Service calls to:</p> <ol style="list-style-type: none"> 1. Correct the installation of your range. 2. Instruct you how to use your range. 3. Replace house fuses or correct house wiring or plumbing. 4. Replace owner-accessible light bulbs. <p>B. Repairs when your range is used in other than normal, single-family household use.</p> <p>C. Pickup and delivery. Your range is designed to be repaired in the home.</p> <p>D. Damage to your range caused by accident, misuse, fire, flood, acts of God, or use of products not approved by Whirlpool.</p> <p>E. Repairs to parts or systems resulting from unauthorized modifications made to the appliance.</p>	

2/99

WHIRLPOOL CORPORATION SHALL NOT BE LIABLE FOR INCIDENTAL OR CONSEQUENTIAL DAMAGES.

Some states do not allow the exclusion or limitation of incidental or consequential damages, so this exclusion or limitation may not apply to you. This warranty gives you specific legal rights, and you may also have other rights which vary from state to state.

Outside the United States, a different warranty may apply. For details, please contact your authorized Whirlpool dealer.

If you need service, first see the "Troubleshooting" section of this book. After checking "Troubleshooting," additional help can be found by checking the "Requesting Assistance or Service" section, or by calling the Whirlpool Consumer Assistance Center telephone number, **1-800-253-1301**, from anywhere in the U.S.A.